



TRIBHUVAN UNIVERSITY
INSITUTE OF ENGINEERING
THAPATHALI CAMPUS

Project Report
On
“Intelligence Automatic Room Power Control”



SUBMITTED BY:
MR. KRISHNA KUMAR SHRESTHA
061/DEX/516”A”

SUBMITTED TO:
DEPARTMENT OF
ELECTRONICS & OMPUTER

Preface

The world today is the modern era of science and technology. In every step and for almost every purpose, various types of modern technologies and techniques have been invented so as to provide a higher degree of efficiency and comfortable life.

Among various technological fields, electronics is one of the emerging technological areas. In fact electronics have grabbed and invaded almost every part of the world. Either it is simple home entertaining equipment or is fields of a satellite communication and computers, electronics have brought up a revolutionary change in neon technology.

Though there are various technological fields, but the only aim of every inventions and discoveries is the provision of maximum comfort, efficient, automatic and time saving for human beings and its associates? Everybody in this world is seeking the system that simulates the features of comfort nest and saving of energy. Also, there desires have been fulfilled by various inventions. Among them electronics have brought up a life that runs with the use of micro equipments by the use of highly integrated circuits (ICs).

Thus, in the step of fulfill the various desire and needs of people, I, as a student of electronics engineering, have accomplished a project that is fully devoted for provision of comfortable life and moreover saving of the power losses.

This project is in titled as “Intelligence Automatic Room Power Control”. This Equipment provides an aid to atomized system that utilizes LDRs, multivibrators, logic unit, counters, memory, relay etc.

I hope this project report will be helpful to everyone especially to use in guest room in hotel and lodges.

Krishna Kumar Shrestha

Acknowledgement

The successful completions of this project “Intelligence Automatic Room Power Control” have been realized by the combined effort and skills of lots of people. As I have achieved a greater success regarding the completion and output of the project. There are a lot of people whose credits of helps are needed to be thankfully acknowledged.

The credits of thanks go out to those all at Electronics department and of my class who have always contributed their time, talent and effort to complete this project, I gratefully like to thank my project supervisor Mr. Santa Maharjan (as well as HOD of the department) for his great supervision, guidance, support and Cooperation.

Finally, I would also like to thank all known hands of my class and campus for their great support and directions during the whole project; in absence of them my project would have been incomplete.

Thank you all!

Krishna Kumar Shrestha
061/DEX/5

@www.erkrishna.com.np

CONTENTS

CHAPTERS:

1. Introduction and Objectives
2. Block Diagram and its Explanation
3. DC power supply
4. Basic knowledge about various electronic components
 - A. Passive components
 - a) Resistors
 - b) Capacitors
 - B. Active components
 - a. Diodes
 - b. Transistors
 - c. Integrated Circuit (IC)
 - Logic Gates
 - Three Terminal Voltage Regular
 - C. Relays
5. Circuit Diagram and its explanation
6. Problems and limitations of the project
7. Cost estimation of Project
8. Discussion and Conclusion
9. Bibliography

APENDIX:

Including required datasheets of decade counter (CD4017), 555 timer IC and logical IC's AND gate (74LS08), NOT gate (74LS04).

Chapter: 1

1. Introduction

As prefaced already this project has been intended for provision of “comfortable life and power”. I have accomplished this project for the partial fulfillment of “Project work II” include in the course of study of III/II of diploma in electronics engineering (DEX).

This project consists of easily available components and has greater applications. Since this project is capable of distinguishing presence people in room, it has been entitled "Intelligent". This project consists of readily available components like resistors, capacitors, diodes, transistors, counters, logical and regular Ics and relay. It also aids in cheaper device. This project also contributes in the manufacture of automatic system that is moreover concerned in saving time as well as electricity.

2. Objectives:

The project is highly devoted in the control of unwanted power loss by switching any electric devices at only our desired time by its intelligent automatic switching circuit. The main objectives of this project are listed below:

- i. To contribute in control system for efficient operation and control over the power losses.
- ii. To operate any electric devices only in the presence of human beings.
- iii. To save time of switching electric devices by human beings themselves.
- iv. .

Chapter: 2

1. Block Diagram

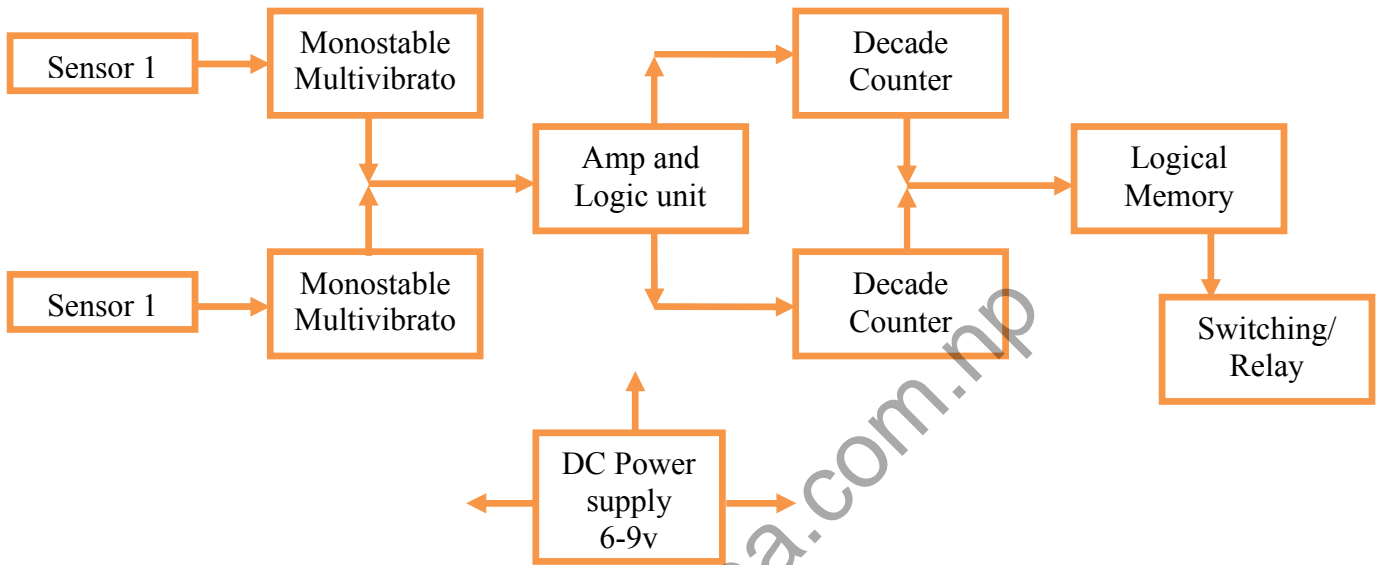

Fig. Block Diagram of **Intelligence Automatic Room Power Control**.

2. Block Explanation

1. Power section

As we know electronics equipment need power supply, my project also use power supply of 6-9dc voltage. This power can feed to it from either dc power supply or Battery. To protect from external pulses I have used a diode and to protect from possible high power I have put a regulator IC between power section and main circuit.

2. Sensor

Sensor section consists of 2 LDRs which senses the light signal from the input source (i.e. shadow of people entered into room) and convert into the corresponding electrical signal as its resistance changes with respect to intensity of light falls on it, and sends it to the pulse trigger circuit (IC NE555). The sensitivity of touch point (action) is adjusted by present R1 and R2.

3. Monostable Multivibrator

The timer IC 555 (14 pin) is connected as monostable multivibrator. Its stable state is low output so when a positive trigger is applied in its input it gives high output only for a fix time and then it again goes low.

4. Amplifier and Logic unit

In this section the output from two sensors is combined to determine either the person is entered into or come out from room. It gives one output from two inputs of sensors and triggers IC 3 if the person is entered into room (indicator **green** Light) and the triggers counter IC 4 if the person comes out from the room (indicator **red** Light)

5. Decade Counter

The circuit uses decade counter it means the counter can count only up to 9 counts and reset at its 10th count. It uses two CD4017 counter IC, one for counting number of people enter into the room (**green** leds) and another for counting number of people coming out from room (**red** leds). But in the project the maximum people can use for control is 4 so the both counter is connected so as it count up to 4 and resets to 0.

6. Logical Memory

It consists of inverter/ NOT gate (IC 5- 74LS04), AND gate (IC 6- 74LS08) and Diodes. The output of counter IC 3 is directly fed into one of the input of each AND gate and output of counter IC 4 is firstly inverted with IC 5 and then fed in next input of each AND gate. All AND gate output is combined in a point from diode to drive the switching transistors. In this way the unit provides high output only during the any person is present in the room. The point to be noted in this block is AND gate gives high only when the both input in it are high and NOT gate gives high output for low input and vice versa.

7. Switching/ Relay

This block is of a switching transistor (SL 100) and a relay. The transistor is on only during any person is left in the room providing the operating voltage for relay to switch on (indicator last red LED). The relay used in this project is simple type (6v, 100 ohm) which has ability of an N/C (normally close) and N/O (normally open) function. Basically we use N/O function though we can use N/C function too as our requirement. It switch on the power supply during any person left in room.

Chapter: 3

3. DC Power Supply

The circuit given above is simplest circuit of regulated dc power supply system; in my project we can use both battery of 0-9V and DC voltage supply, among them DC voltage supply 0-9V from 230V is most effective, so I use this type of supply in the project. The circuit diagram of regulated DC power supply is given here.

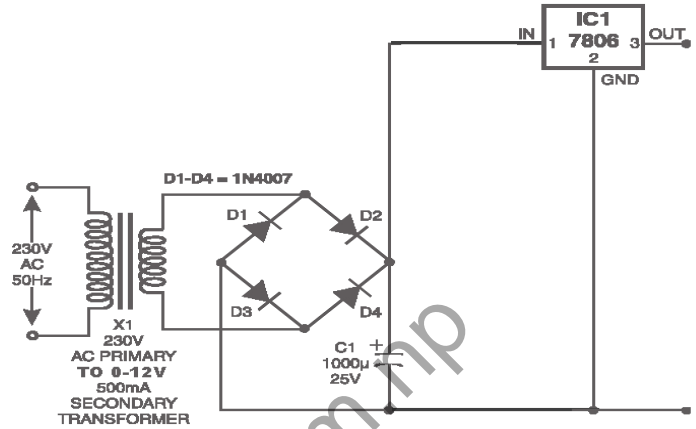

@www.erkrishna.com/np

Chapter: 4

4. Basic knowledge about various electronic components

A. Passive components

Since we can divide all the electronics components into active and **passives**. Components that a control energy but can't amplify or modify one form of energy to another are known as passive components. All non semiconductor devices are passive components. Passive components used in this project are **Resistors, Capacitors and Inductor** (in relay and transformer).

a. Resistors:

The resistor's function is to reduce the flow of electric current. This symbol $\text{---}\text{W}\text{---}$ is used to indicate a resistor in a circuit diagram, known as a schematic. Resistance value is designated in units called the "Ohm." A 1000 Ohm resistor is typically shown as 1K-Ohm (kilo Ohm), and 1000 K-Ohms is written as 1M-Ohm (mega ohm). There are two classes of resistors; **Fixed Resistors** and the **Variable Resistors**. They are also classified according to the material from which they are made. The typical resistor is made of either carbon film or metal film. There are other types as well, but these are the most common.

The resistance value of the resistor is not the only thing to consider when selecting a resistor for use in a circuit. The "tolerance" and the electric power ratings of the resistor are also important. The tolerance of a resistor denotes how close it is to the actual rated resistance value. For example, a $\pm 5\%$ tolerance would indicate a resistor that is within $\pm 5\%$ of the specified resistance value.

The power rating indicates how much power the resistor can safely tolerate. Just like you wouldn't use a 6 volt flashlight lamp to replace a burned out light in your house, you wouldn't use a 1/8 watt resistor when you should be using a 1/2 watt resistor. The maximum rated power of the resistor is specified in Watts. Power is calculated using the square of the current (I^2) x the resistance value (R) of the resistor. If the maximum rating of the resistor is exceeded, it will become extremely hot and even burn. Resistors in electronic circuits are typically rated 1/8W, 1/4W, and 1/2W. 1/8W is almost always used in signal circuit applications. When powering a light emitting diode, a comparatively large current flow through the resistor, so you need to consider the power rating of the resistor you choose.

b. Capacitors:

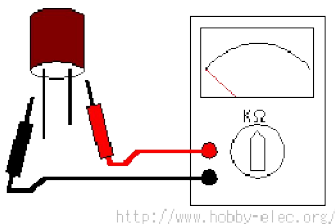

The capacitor's function is to store electricity, or electrical energy. The capacitor also functions as a filter, passing alternating current (AC), and blocking direct current (DC). This symbol $\text{---}| \text{---}|$ is used to indicate a capacitor in a circuit diagram. The capacitor is constructed with two electrode plates facing each other, but separated by an insulator. When DC voltage is applied to the capacitor, *an electric charge* is stored on each electrode. While the capacitor is charging up, current flows. The current will stop flowing when the capacitor has fully charged. The

capacitor's function is to store electricity, or electrical energy. The capacitor also functions as a

filter, passing alternating current (AC), and blocking direct current (DC). This symbol $\text{—}||\text{—}$ is used to indicate a capacitor in a circuit diagram. The capacitor is constructed with two electrode plates facing each other, but separated by an insulator.

When DC voltage is applied to the capacitor, *an electric charge* is stored on each electrode. While the capacitor is charging up, current flows. The current will stop flowing when the capacitor has fully charged.

The value of a capacitor (the capacitance), is designated in units called the Farad (F). The capacitance of a capacitor is generally very small, so units such as the microfarad (10^{-6}F), nano farad (10^{-9}F), and Pico farad (10^{-12}F) are used. Recently, a new capacitor with very high capacitance has been developed. The Electric Double Layer capacitor has capacitance designated in Farad units. These are known as “Super Capacitors.”

Sometimes, a three-digit code is used to indicate the value of a capacitor. There are two ways in which the capacitance can be written. One uses letters and numbers, the other uses only numbers. In either case, there are only three characters used. [10n] and [103] denote the same value of capacitance. The method used differs depending on the capacitor supplier. In the case that the value is displayed with the three-digit code, the 1st and 2nd digits from the left show the 1st figure and the 2nd figure, and the 3rd digit is a multiplier which determines how many zeros are to be added to the capacitance. Pico farad (pF) units are written this way. For example, when the code is [103], it indicates 10×10^3 , or $10,000\text{pF} = 10 \text{ nano farad (nF)} = 0.01 \text{ microfarad } (\mu\text{F})$. If the code happened to be [224], it would be $22 \times 10^4 =$ or $220,000\text{pF} = 220\text{nF} = 0.22\mu\text{F}$. Values under 100pF are displayed with 2 digits only. For example, 47 would be 47pF . The capacitor has an insulator (the dielectric) between 2 sheets of electrodes. Different kinds of capacitors use different materials for the dielectric.

Breakdown voltage

When using a capacitor, you must pay attention to the maximum voltage which can be used. This is the “breakdown voltage.” The breakdown voltage depends on the kind of capacitor being used. You must be especially careful with electrolytic capacitors because the breakdown voltage is comparatively low. The breakdown voltage of electrolytic capacitors is displayed as Working Voltage. The breakdown voltage is the voltage that when exceeded will cause the dielectric (insulator) inside the capacitor to break down and conduct. When this happens, the failure can be catastrophic.

Electrolytic Capacitors (Electrochemical type capacitors)

Aluminium is used for the electrodes by using a thin oxidation membrane. Large values of capacitance can be obtained in comparison with the size of the capacitor, because the dielectric used is very thin. The most important characteristic of electrolytic capacitors is that they have polarity. They have a positive and a negative electrode. [Polarised]

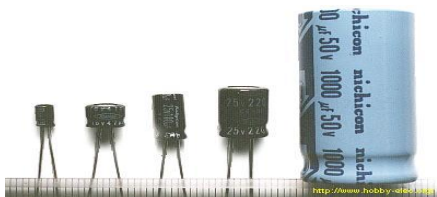

This means that it is very important which way round they are connected. If the capacitor is subjected to voltage exceeding its working voltage, or if it is connected with incorrect polarity, it may burst. It is extremely dangerous, because it can quite literally explode. **Make absolutely no mistakes.** Generally, in the circuit diagram, the positive side is indicated by a “+”

(plus) symbol. Electrolytic capacitors range in value from about $1\mu\text{F}$ to thousands of μF . Mainly this type of capacitor is used as a ripple filter in a power supply circuit, or as a filter to bypass low frequency signals, etc. Because this type of capacitor is comparatively similar to the nature of a coil in construction, it isn't possible to use for high-frequency circuits. (It is said that the frequency characteristic is bad.)

Ceramic Capacitors

Ceramic capacitors are constructed with materials such as titanium acid barium used as the dielectric. Internally, these capacitors are not constructed as oil, so they can be used in high frequency applications. Typically, they are used in circuits which bypass high frequency signals to ground. These capacitors have the shape of a disk. Their capacitance is comparatively small.

The capacitor on the left is a 100pF capacitor with a diameter of about 3 mm. The capacitor on the right side is printed with 103, so $10 \times 10^3\text{pF}$ becomes $0.01\mu\text{F}$. The diameter of the disk is about 6 mm. Ceramic capacitors have no polarity. Ceramic capacitors should not be used for analogue circuits, because they can distort the signal.



c. Coils (Inductors):

A coil is nothing more than copper wire wound in a spiral. This symbol  is used to indicate a coil in a circuit diagram. Inductance value is designated in units called the Henry (H). The more wire the coil contains, the stronger its characteristics become. The inductance value can become quite large. If a coil is wound around an iron rod, or ferrite core (strengthened with iron powder), the inductance of the coil will be greatly increased. Coils used in typical electric circuits' varied widely in values, ranging from a few micro-henrys (μH) to many henrys (H). Coils are sometimes called "inductors." Inductance is the measure of the strength of a coil. Capacitors have capacitance, resistors have resistance, and Inductors (coils) have inductance. When alternating current flows through a coil, the magnetic flux that occurs in the coil changes with the current. When a second coil is put close to the first coil (with the changing flux), alternating voltage is caused to flow in the second coil by an effect known as "mutual induction." Mutual inductance (inductance) is measured in units of the Henry. The changing magnetic flux in a coil affects itself as well as other coils. This is called self induction; the degree of this self induction is called Self Inductance. Self inductance is a measure of a coil's ability to establish an induced voltage as a result of a change in its current. Self inductance is commonly referred to as simply "inductance," and is symbolized by "L". The unit of inductance is the Henry (H).

The definition of "Henry" is "When a current of 1 ampere flows through a given coil in 1 second such that 1 volt is induced to flow in a second coil, the mutual inductance between the coils is said to be 1 Henry." The definition of self inductance is the same, except that the 1 volt is induced in the first coil; there is no second coil.

Electromagnetic Relay utilizes the coil. When the current flows to the coil of relay, the magnetic field attracts a steel plate, and the switch that is attached to the steel plate goes ON. And the doorbell chime also utilizes electromagnets.



B. Active components

Components that can rectify, amplify or change one form of energy to another form are known as active components. All semiconductor devices are active components. Active components used in the project are **Diodes, Transistors, and Gates.**

a. Diodes:

A diode is a semiconductor device which allows current to flow through it in only one direction. Although a transistor is also a semiconductor device, it does not operate the way a diode does. A diode is specifically made to allow current to flow through it in only one direction. Some ways in which the diode can be used are listed here.

- A diode can be used as a rectifier that converts AC (Alternating Current) to DC (Direct Current) for a power supply device.
- Diodes can be used to separate the signal from radio frequencies.
- Diodes can be used as an on/off switch that controls current.

This symbol  is used to indicate a diode in a circuit diagram. The meaning of the symbol is (Anode)  (Cathode). Current flows from the anode side to the cathode side. Although all diodes operate with the same general principle, there are different types suited to different applications. For example, the following devices are best used for the applications noted.

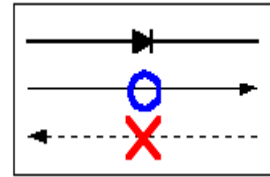

Light emitting diode

The circuit symbol is . This type of diode emits light when current flows through it in the forward direction. (Forward biased.)

b. Transistors:

The transistor's function is to amplify an electric current. Many different kinds of transistors are used in analogue circuits, for different reasons. This is not the case for digital circuits. In a digital circuit, only two values matter; on or off. The amplification ability of a transistor is not relevant in a digital circuit. In many cases, a circuit is built with integrated circuits (Ics). Transistors are often used in digital circuits as buffers to protect Ics. For example, when powering an electromagnetic switch (called a 'relay'). Two different symbols are used for the transistor.

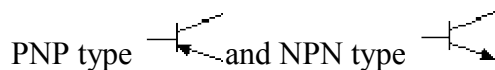

c. Integrated Circuits:

An integrated circuit contains transistors, capacitors, resistors and other parts packed in high density on one chip. Although the function is similar to a circuit made with separate components, the internal structure of the components are different in an integrated circuit. The transistors, resistors, and capacitors are formed very small, and in high density on a foundation of silicon. They are formed by a variation of printing technology. There are many kinds of Ics, including special use Ics. The top left device in the photograph is an SN7400. It contains 4 separate “2 input NAND” circuits. There are 7 pins on each side, 14 pins total. Ics in this form are called Dual In line Package (DIP).When an IC has only one row of pins, it is called a Single in line Package (SIP).The number of pins changes depending on the function of IC. At the bottom left is an IC socket for use with 14 pin DIP Ics. Ics can be attached directly to the printed circuit board with solder, but it’s better to use an IC socket, because you can easily exchange it should the IC fail. On the top right is an LM386N audio amplifier. It can be used for amplification of low frequency, low power signals. IT has 8 pins and the maximum output is 660mW.On the bottom right is a TA7368P, which also is for amplification of low frequency electric power. It has a maximum output of 1.1 watts. It is a 9 pin SIP IC.

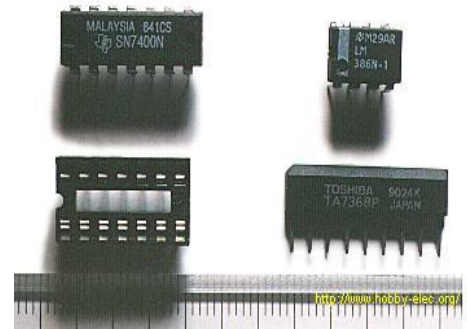

i. Logic Gates:

Logic gates are the electronics circuits which makes logic decisions. It has one output and one or more inputs and the output signals appear for combination of input signals. Logic gates are basic blocks for building the digital system. They implement the hardware logic based on logical algebra called Boolean algebra.

This system can available only in various IC; The symbols of logic gates OR, AND, NOT, NAND, NOR, X-OR, X-NOR are respectively shown in fig below:

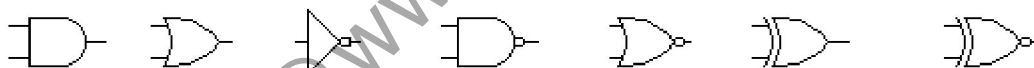

Digital logic is a rational process for making simple “true” or “false” decisions based on the rules of Boolean algebra. “True” can be represented by a 1 and “false” by a 0, digital logic is a rational process for making simple “true” or “false” decisions based on the rules of Boolean algebra. “True” can be represented by a 1 and “false” by a 0, and in logic circuits the numerals appear as signals of two different voltages. Logic circuits are used to make specific true-false decisions based on the presence of multiple true-false signals at the inputs. The signals may be generated by mechanical switches or by solid-state transducers. Once the input signal has been accepted and conditioned (to remove unwanted electrical signals, or “noise”), it is processed by the digital logic circuits. The various families of digital logic devices, usually integrated circuits, perform a variety of logic functions through logic gates, including “OR,” “AND,” and “NOT,” and combinations of these (such as “NOR,” which includes both OR and NOT). One widely used logic family is the transistor-transistor logic (TTL). Another family is the complementary metal oxide semiconductor logic (CMOS), which performs similar functions at very low power levels but at slightly lower operating speeds. Several other, less popular families of logic circuits exist, including the currently

obsolete resistor-transistor logic (RTL) and the emitter coupled logic (ELC), the latter used for very-high-speed systems.

Classification of Logic Gates:

- Basic Gates (AND, OR, NOT)
- Universal Gates (NAND, NOR)
- Other Gates (X-OR, X-NOR, ...)

The truth table of logic gates:

Two inputs		Various Gates outputs					
A	B	AND	OR	NAND	NOR	X-OR	X-NOR
0	0	0	0	1	1	0	1
0	1	0	1	1	0	1	0
1	0	0	1	1	0	1	0
1	1	1	1	0	0	0	1

ii. Three Terminal Voltage Regulator

It is very easy to get stabilized voltage for ICs by using a three terminal voltage regulator. The power supply voltage for a car is +12V - +14V. At this voltage, some ICs can not operate directly except for the car component ICs. In this case, a three terminal voltage regulator is necessary to get the required voltage. The three terminal voltage regulator outputs stabilized voltage at a lower level than the higher input voltage. A voltage regulator cannot put out higher voltage than the input voltage. They are similar in appearance to a transistor. On the left in the photograph is a 78L05. The size and form is similar to a 2SC1815 transistor. The output voltage is +5V, and the maximum output current is about 100mA. The maximum input voltage is +35V. (Differs by manufacturer.) On the right is a 7805. The output voltage is +5V, and maximum output current is 500mA to 1A. (It depends on the heat sink used)The maximum input voltage is also +35V. There is many types with different output voltages. 5V, 6V, 7V, 8V, 9V, 10V, 12V, 15V, 18V

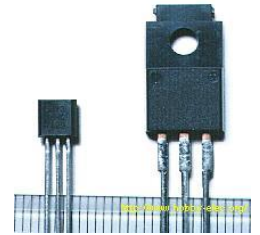

C. Relay:

This is electrical switch having two possible connections known as normally contact (NC) and normally open (NO). Without voltage supply the NC is on mode and NO is off while with voltage supply in relay coil NC is off and NO is on mode it means the voltage in relay opponent the switching. It should choose of proper voltage, resistance and current range.

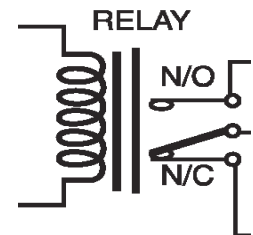

5. Circuit Diagram and its explanation

Circuit diagram:

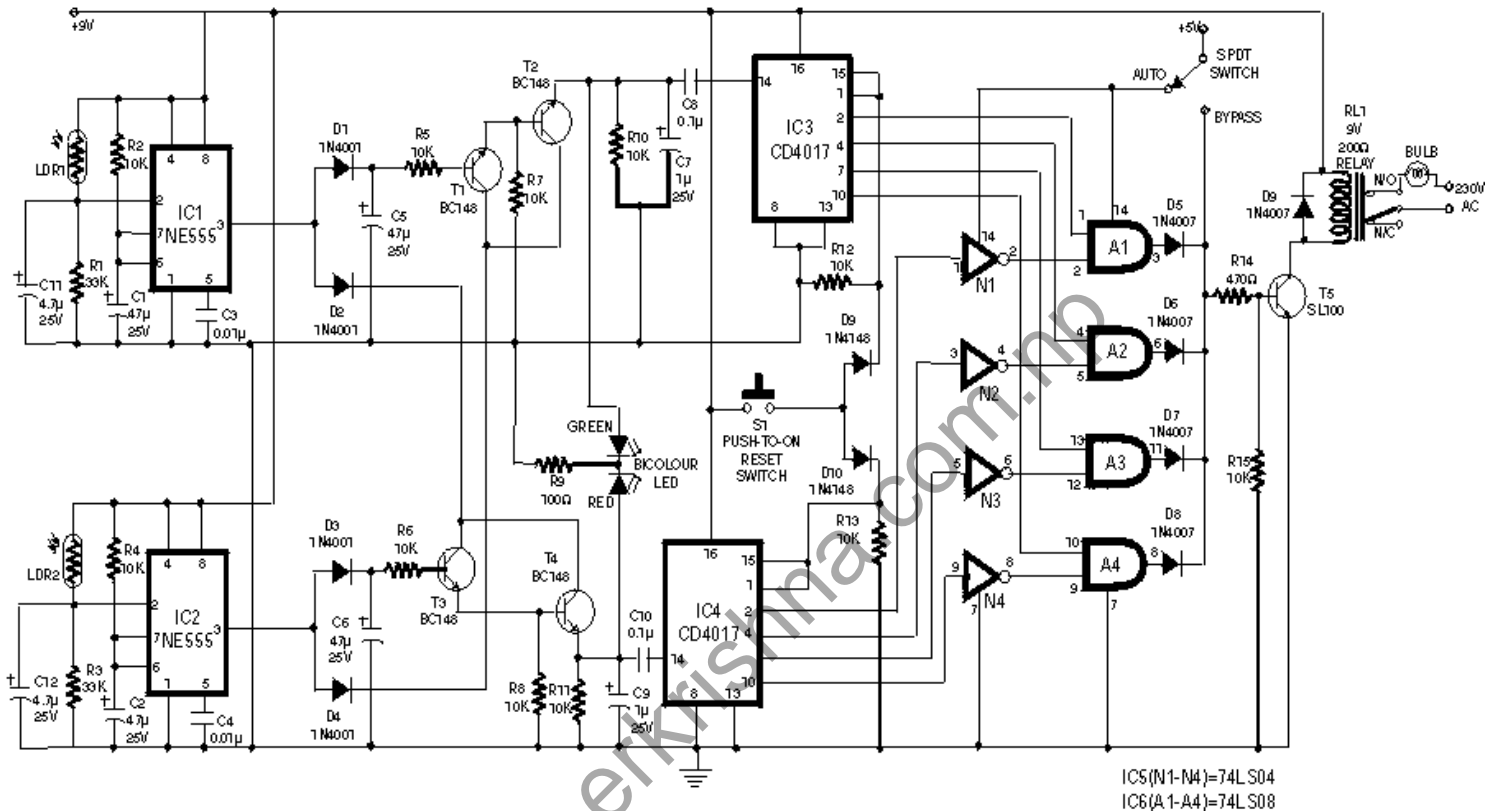

Fig: Circuit diagram of "Intelligence Automatic Room Power Control"

Circuit Explanation:

The circuit diagram of "Intelligence Automatic Room Power Control" is shown in above diagram.

An ordinary automatic room power control circuit has only one light sensor. So when a person enters the room it gets one pulse and the lights come 'on.' When the person goes out it gets another pulse and the lights go 'off.' But what happens when two persons enter the room, one after the other? It gets two pulses and the lights remain in 'off' state. The circuit described here overcomes the above-mentioned problem. It has a small memory which enables it to automatically switch 'on' and switch 'off' the lights in a desired fashion.

The circuit uses two LDRs which are placed one after another (separated by a distance of say half a metre) so that they may separately sense a person going into the room or coming out of the room. Outputs of the two LDR sensors, after processing, are used in conjunction with a bicolour LED in such a fashion that when a person gets into the room it emits green light and when a person goes out of the room it emits red light, and vice versa. These outputs are simultaneously applied to two counters. One of the counters will count as +1, +2, +3 etc when persons are

getting into the room and the other will count as -1, -2, -3 etc when persons are getting out of the room. These counters make use of Johnson decade counter CD4017 ICs.

The next stage comprises two logic ICs which can combine the outputs of the two counters and determine if there is any person still left in the room or not. Since in the circuit LDRs have been used, care should be taken to protect them from ambient light. If desired, one may use readily available IR sensor modules to replace the LDRs.

The sensors are installed in such a way that when a person enters or leaves the room, he intercepts the light falling on them sequentially—one after the other. When a person enters the room, first he would obstruct the light falling on LDR1, followed by that falling on LDR2. When a person leaves the room it will be the other way round. In the normal case light keeps falling on both the LDRs, and as such their resistance is low (about 5 kilo-ohms). As a result, pin 2 of both timers (IC1 and IC2), which have been configured as monostable flip-flops, are held near the supply voltage (+9V). When the light falling on the LDRs is obstructed, their resistance becomes very high and pin 2 voltages drop to near ground potential, thereby triggering the flip-flops. Capacitors across pin 2 and ground have been added to avoid false triggering due to electrical noise.

When a person enters the room, LDR1 is triggered first and it results in triggering of monostable IC1. The short output pulse immediately charges up capacitor C5, forward biasing transistor pair T1-T2. But at this instant the collectors of transistors T1 and T2 are in high impedance state as IC2 pin 3 is at low potential and diode D4 is not conducting. But when the same person passes LDR2, IC2 monostable flip-flop is triggered. Its pin 3 goes high and this potential is coupled to transistor pair T1-T2 via diode D4. As a result transistor pair T1-T2 conducts because capacitor C5 retains the charge for some time as its discharge time is controlled by resistor R5 (and R7 to an extent). Thus green LED portion of bi-colour LED is lit momentarily. The same output is also coupled to IC3 for which it acts as a clock. With entry of each person IC3 output (high state) keeps advancing. At this stage transistor pair T3-T4 cannot conduct because output pin 3 of IC1 is no longer positive as its output pulse duration is quite short and hence transistor collectors are in high impedance state.

When persons leave the room, LDR2 is triggered first followed by LDR1. Since the bottom half portion of circuit is identical to top half, this time with the departure of each person red portion of bi-colour LED is lit momentarily and output of IC4 advances in the same fashion as in case of IC3.

The outputs of IC3 and those of IC4 (after inversion by inverter gates N1 through N4) are ANDed by AND gates (A1 through A4) are then wire ORed (using diodes D5 through D8). The net effect is that when persons are entering, the output of at least one of the AND gates is high, causing transistor T5 to conduct and energise relay RL1. The bulb connected to the supply via N/O contact of relay RL1 also lights up. When persons are leaving the room, and till all the persons who entered the room have left, the wired OR output continues to remain high, i.e. the bulb continues to remain 'on,' until all persons who entered the room have left.

The maximum number of persons that this circuit can handle is limited to four since on receipt of fifth clock pulse the counters are reset. The capacity of the circuit can be easily extended for up to nine persons by removing the connection of pin 1 from reset pin (15) and utilising Q1 to Q9 outputs of CD4017 counters. Additional inverters, AND gates and diodes will, however, be required.

The circuit should be provided with 9v supply except for two logic Ics (74LS04 and 74LS08), which should be given with 5v.

Chapter: 6

6. Problems and limitations of the project

Problems, their solution and limitations:

The main problems faced during the project and their solutions are:

1. Due to sensitivity of circuit even a negligible shadow effect the project for miss triggering and counting.
2. Although I had increased the sensitivity of sensor for proper shadow detection sometimes even due to variation of the speed, men entered into the room is not detected properly.
3. Unavailability of components like 100 ohm relay, we use 6 v relay, neglecting resistance.

Limitation of the project:

1. This project can't work in dark place because it determines the presence of men by sensing the shadow dropped on LDRs surface.
2. The project can't work if more than 4 people are entered inside room.

Chapter: 7

7. Cost Estimation of Components use in Project:

S.N	Items	Code/value	Quantity	Rate	Total price
1.	LDR	-	2	15	30
2.	Transistor	BC548	4	10	40
3.	Transistor	SL100	1	20	20
4.	Ceramic Capacitor	0.01 μ	2	5	10
5.	Ceramic Capacitor	0.1 μ	2	5	10
6.	Capacitor	4.7 μ f,25v	2	10	20
7.	Capacitor	47 μ ,25v	4	12	48
8.	Capacitor	1 μ ,25v	2	8	16
9.	Preset	50k	2	15	30
10.	Resistors	10k	11	2	22
11.	Resistors	470 Ω	2	2	4
10.	Diode	1N4148	2	5	10
11.	Diode	1N4001	9	4	36
12.	Relay	6v, 250 ohm, SPDT	1	60	60
13.	Reset Switch	Push to On	1	20	20
14.	Socket	3 output	1	20	20
15.	Timer IC	NE555	2	20	40
16.	Dot PCB	-	1	50	50
17.	Bread Board	-	2	200	400
18.	Cover	-	1	150	150
19.	LED	Red, Green, yellow	13	5	65
20.	Counter IC	CD4017	2	70	140
21.	NOT gate	74LS04	1	70	70
22.	AND gate	74LS08	1	70	70
23.	Total		1	-	1221
24.	Overhead cost	Total +30% of total cost = 1221+366.3= 1587.3NRS			

Chapter: 8

8. Discussion and Conclusion

Discussion

Though this is my second formal project, I never gave up hope during operations of project. Since I always desire to make useful electronic equipments for people, I make intelligence Automatic Room Power Control, which is useful for all the people for small works to control power and save time as it control power automatically and provide power supply only during the presence of men in room and saves the time of switching too.

I get lots of problems during the project which I have solved nearly completely by the various observations and by the help of my coordinator. Such as when my project was disturbed by light variation I used variable resistor by replacing fix resistors in series with LDR to change its sensitivity.

The main problem of the project is in sensor and logic section, the logical decision is effected even by the speed of men inter into the room. Also the LDR sensor is very sensitive to light, it is affected even by weather, the sequence detector is not practicable too so to use the project practically the sensor must replace by IR sensor and the reliable triggering and logic unit too to decide properly that either the man entered into the room or comes out from room.

Conclusion

During project period, the interaction, so-coordination with my supervisor teachers and colleagues made me know about the importance of team work. This project through all its hindrances and obstacles was completed successfully to the greater extent that we can expect in the time boundary. After the successful completion of the project, I concluded that the project is really of great importance.

Chapter: 9

9. Bibliography:

1. Internet
2. Principle Of Electronics.....V.K & ROHIT MEHTA
3. Digital Fundamentals.....Thomas. L. Floyd
4. Electrical Technology.....B. L. Theraja & A.K. Theraja
5. Basic Electronics.....Gt. Publication

@www.erkrishna.com.np

Appendix:

Required datasheets of decade counter CD4017, 555 timer IC and logical Ics, AND gate (74LS08), NOT gate (74LS04).

@www.erkrishna.com.np